

## 1.5MHz, 1.0A Synchronous Step-Down Converter

### General Description

The PN6510 is a high efficiency monolithic synchronous buck regulator using a constant frequency, current mode architecture. The device is available in an adjustable version and fixed output voltages, such as 1.2V, 1.5V, 1.8V, etc. Supply current with no load is 300uA and drops to <1uA in shutdown. The 2.5V to 6.5V input voltage range makes the PN6510 ideally suited for single Li-Ion, two to four AA battery-powered applications. 100% duty cycle provides low dropout operation, extending battery life in portable systems. PWM pulse skipping mode operation provides very low output ripple voltage for noise sensitive applications. Switching frequency is internally set at 1.5MHz, allowing the use of small surface mount inductors and capacitors. The internal synchronous switch increases efficiency and eliminates the need for an external Schottky diode. Low output voltages are easily supported with the 0.6V feedback reference voltage. The PN6510 is available in a small SOT package.

### Applications

- Cellular and Smart Phones
- Microprocessors and DSP Core Supplies
- Wireless and DSL Modems
- PDAs
- MP3 / MP4 /PMP Player
- Digital Still and Video Cameras
- Portable Instruments

### Typical Application Circuit

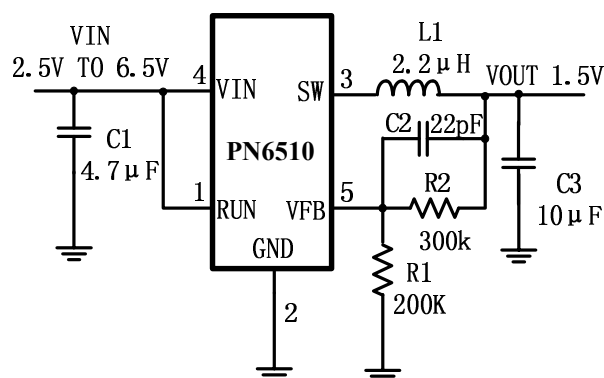

Figure 1. Basic Application Circuit with PN6510 adjustable version

### Features

- High Efficiency: Up to 96%
- 1.5MHz Constant Switching Frequency
- 1.0A Output Current at VIN=3V
- Integrated Main switch and synchronous rectifier. No Schottky Diode Required
- 2.5V to 6.5V Input Voltage Range
- Output Voltage as Low as 0.6V
- 100% Duty Cycle in Dropout
- Quiescent Current: 300µA(input < 4.2V)
- Slope Compensated Current Mode Control for Excellent Line and Load Transient Response
- Short Circuit Protection
- <1uA Shutdown Current
- Soft start
- Space Saving 5-Pin SOT23 package

### Package

SOT23-5L

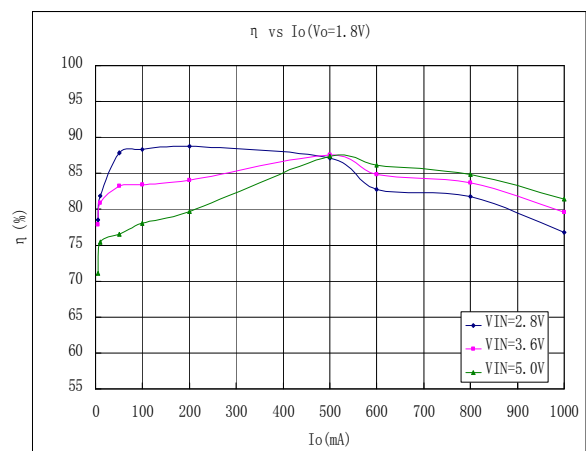
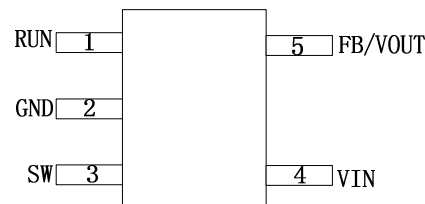

Figure 2. Typical Efficiency Curve