

3A, 18V Synchronous Rectified Step-Down Converter

General Description

The PN1830A is a monolithic synchronous buck regulator. The device integrates 100mΩ MOSFETS that provide 3A continuous load current over a wide operating input voltage of 4.75V to 18V. Current mode control provides fast transient response and cycle-by-cycle current limit.

An adjustable soft-start prevents inrush current at turn-on. In shutdown mode, the supply current drops below 1μA.

This device, available in an 8-pin SOP package, provides a very compact system solution with minimal reliance on external components.

Applications

- Distributed Power Systems
- Networking Systems
- FPGA, DSP, ASIC Power Supplies
- Green Electronics/ Appliances
- Notebook Computers

Features

- 3A Output Current
- Wide 4.75V to 18V Operating Input Range
- Integrated 100mΩ Power MOSFET Switches
- Output Adjustable from 0.925V to 15V
- Up to 95% Efficiency
- Programmable Soft-Start
- Stable with Low ESR Ceramic Output Capacitors
- Fixed 370KHz Frequency
- Cycle-by-Cycle Over Current Protection
- Input Under Voltage Lockout
- Thermally Enhanced 8-Pin SOP Package

Package

SOP8-PP

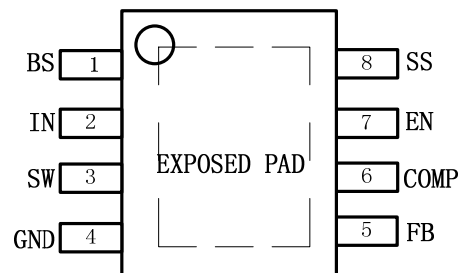

Typical Application Circuit

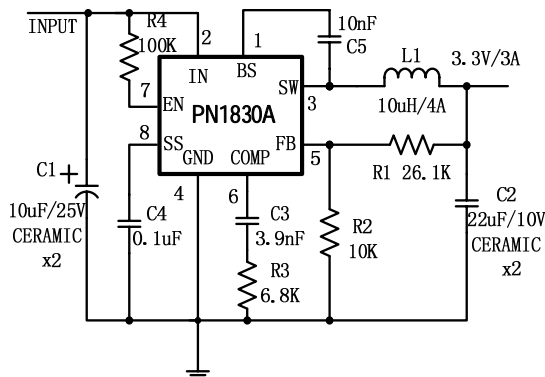

Figure 1. Typical Application Circuit

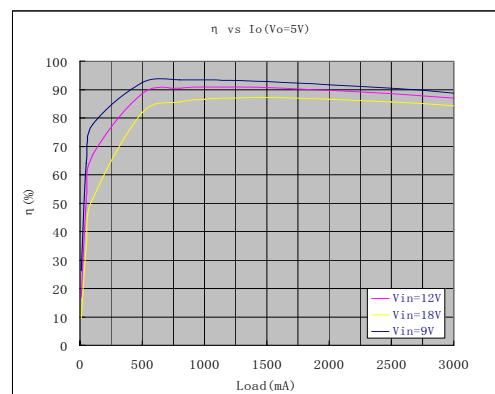

Figure 2. Typical Efficiency Curve