

Synchronous PFM step-up DC-DC converter

General Description

The PN2203 Series is a CMOS PFM-control step-up switching regulator that mainly consists of a reference voltage source, an oscillator, and a comparator, enabling products with a low ripple over a wide range, high efficiency, and high output current. With the PN2203 Series, a step-up switching regulator can be configured by using an external coil and capacitor. A protection circuit turns off the built-in MOS FET when the voltage at the CONT pin exceeds the limit to prevent it from being damaged. This feature, along with the mini package and low current consumption, makes the PN2203 Series ideal for applications such as the power supply unit of portable equipment.

Applications

- Power supply for portable equipment such as digital cameras, electronic notebooks, and PDA
- Power supply for audio equipment such as portable CD/MD players
- Constant voltage power supply for cameras, video equipment, and communications equipment
- Power supply for microcomputers

Features

- High efficiency:95%
- Highest switching frequency:300KHz
- Low input current: 15uA
- Output voltage:2.5~5.0V(step 0.1V)
- Accuracy of $\pm 2.5\%$
- Input voltage:0.9V~5.0V
- Low Ripple, Low Noise

Package

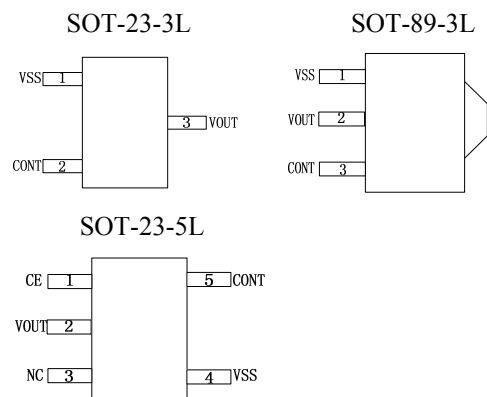

Typical Application Circuit

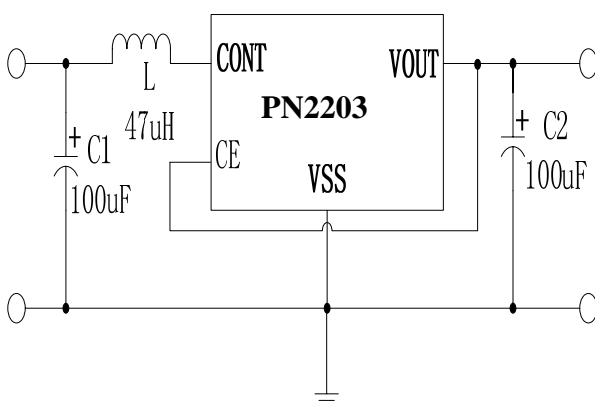

Figure 1. Basic Application Circuit

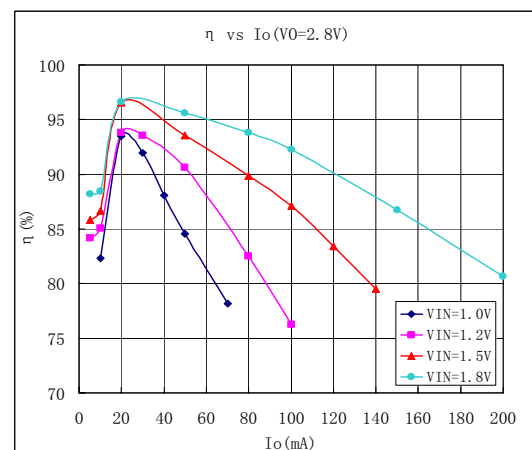

Figure 2. Typical Efficiency Curve