

DUAL N-CHANNEL ENHANCEMENT MODE

■ FEATURES

- * 20V/6A
- * Low $R_{DS(ON)}$
- * Reliable and RuggedPN

■ SYMBOL

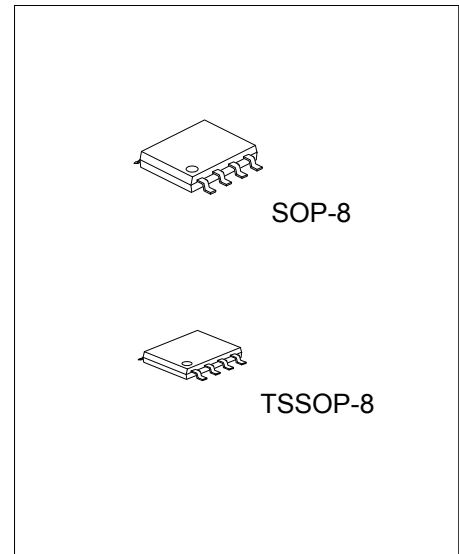
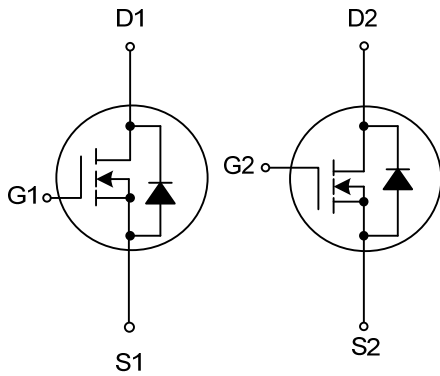

Lead-free: PN9926L
Halogen-free:PN9926G

■ ORDERING INFORMATION

Ordering Number			Package	Pin Assignment								Packing
Normal	Lead Free Plating	Halogen Free		1	2	3	4	5	6	7	8	
PN9926-S08-R	PN9926L-S08-R	PN9926G-S08-R	SOP-8	S1	G1	S2	G2	D2	D2	D1	D1	Tape Reel
PN9926-P08-R	PN9926L-P08-R	PN9926G-P08-R	TSSOP-8	D1	S1	S1	G1	G2	S2	S2	D2	Tape Reel

<p>PN9926 L-S08-R</p> <ul style="list-style-type: none"> (1)Packing Type (2)Package Type (3)Lead Plating 	<ul style="list-style-type: none"> (1) R: Tape Reel (2) S08: SOP-8, P08: TSSOP-8 (3) G: Halogen Free, L: Lead Free, Blank: Pb/Sn
--	---